

China direct factory supply chain scraper conveyor machine for ash pulverized coal

Product Description

Scraper conveyor is a transportation machine used in coal mining face. It is mainly used for transporting along the trough in coal mining face and mining area, and can also be used in coal roadway and semi-coal roadway excavation face. It can be transported upwards or downwards, and the upward transport generally does not exceed 35 degrees. The downward transportation generally does not exceed 25 degrees, and it is advisable not to exceed 20 degrees in practice.

Product Structure

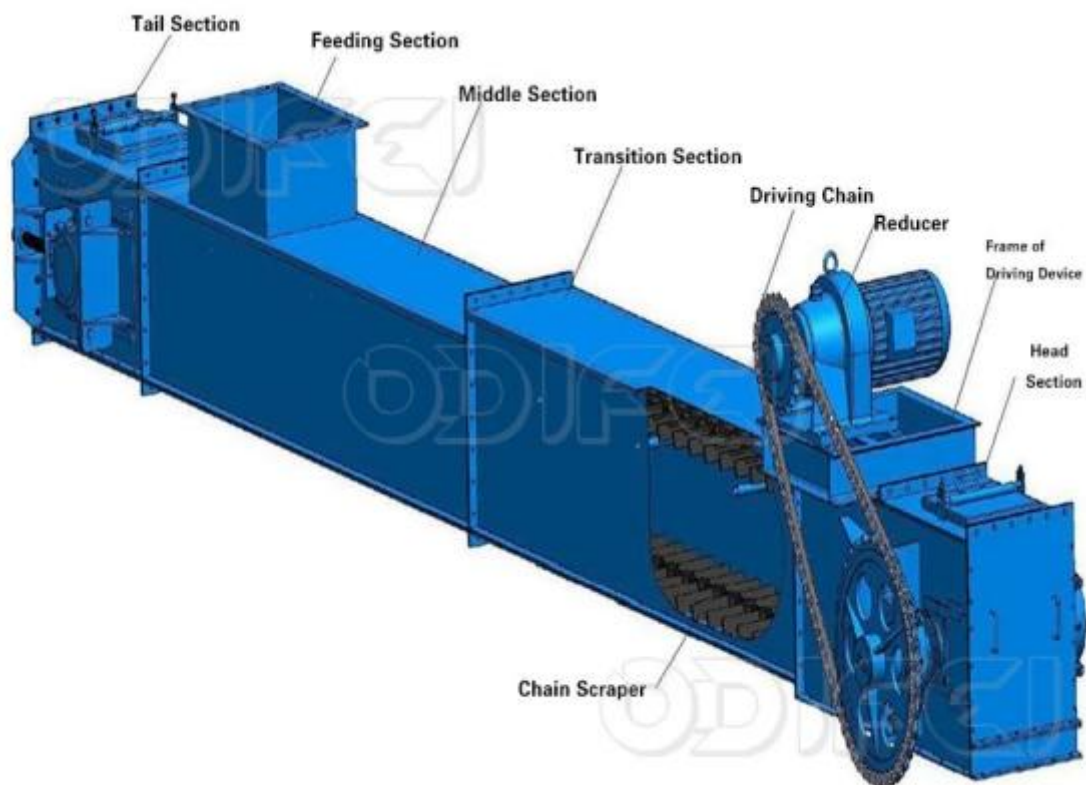

It is mainly composed of a closed section shell (machine tank), scraper chain, driving device and tensioning device and other components.

The common process layout structure is shown in the figure

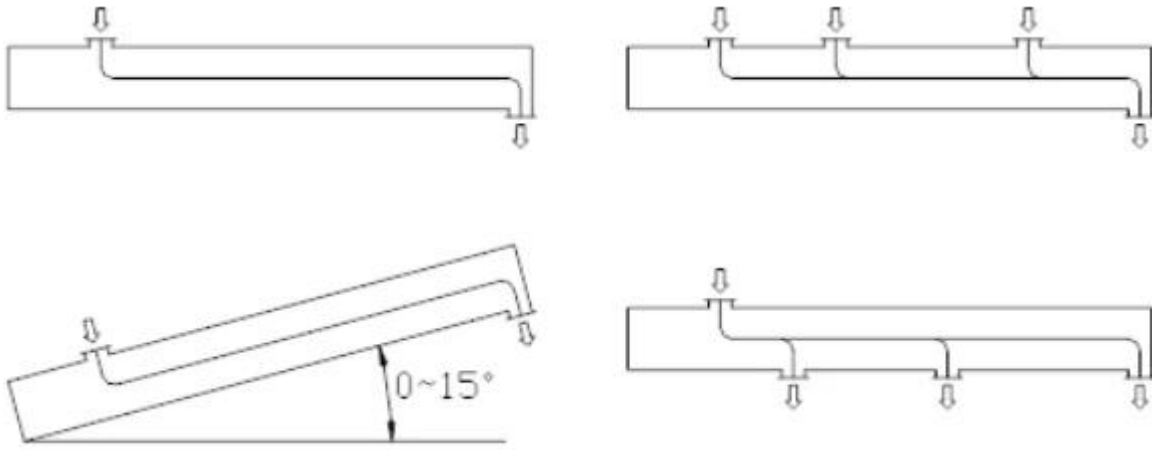

Equipment features of FU scraper conveyor:

1. The equipment has simple structure, small size, good sealing performance, and convenient installation and maintenance;
2. Multi-point feeding and multi-point unloading are possible, and the process selection and layout are more flexible;
3. When transporting flying, toxic, high-temperature, flammable and explosive materials, it can improve working conditions and reduce environmental pollution.

FU scraper conveyor model parameter table:

Model Name	FU200	FU270	FU350	FU410	FU500
Groove width(mm)	200	270	350	410	500
Delivery capacity(m ³ /h)	10-30	20-60	35-100	50-130	80-200
Chain speed(m/min)	10-30	10-30	12-30	12-25	12-30
Chain pitch(mm)	125	185	200	200	300
Conveying distance(m)	8-50	8-50	8-50	8-50	8-50
climbing angle	≤15°				
Motor Power(kw)	2.2-7.5	3-15	4-22	4-30	5.5-45
Drive installation form	left and right,back mounted				
Transmission form	transmission				
Applicable granularity(mm)	<5	<7	<9	<11	<25
Material applicable humidity(%)	≤5				
proper temperature(°C)	≤150				

Product Application:

The scraper conveyor series products are widely used in metallurgy, building materials, electric power, chemical industry, cement, port, wharf, coal, mine, grain and oil, food, feed, and other industries and departments.

THE APPLICATION FIELD IS VERY WIDE



FEED



METALLURGICAL



BUILDING



CHEMICAL



MINE



COAL

Company after-sales service:

- 1.Free offering design solution
- 2.Free technical guidance
- 3.Prompt response (in 24 hours)
- 4.Warranty 1 year, lifetime maintenance
- 5.Site installation and commissioning